

(No Model.)

3 Sheets—Sheet 1.

R. S. WOOD & E. N. DUNDERDALE.

MACHINE FOR CHAMFERING AND FACING SCREW NUTS.

No. 371,654.

Patented Oct. 18, 1887.

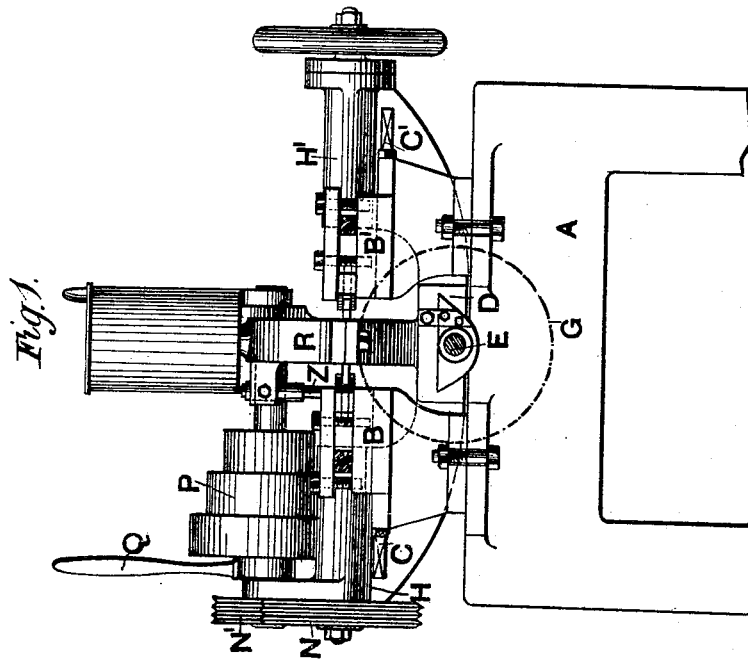
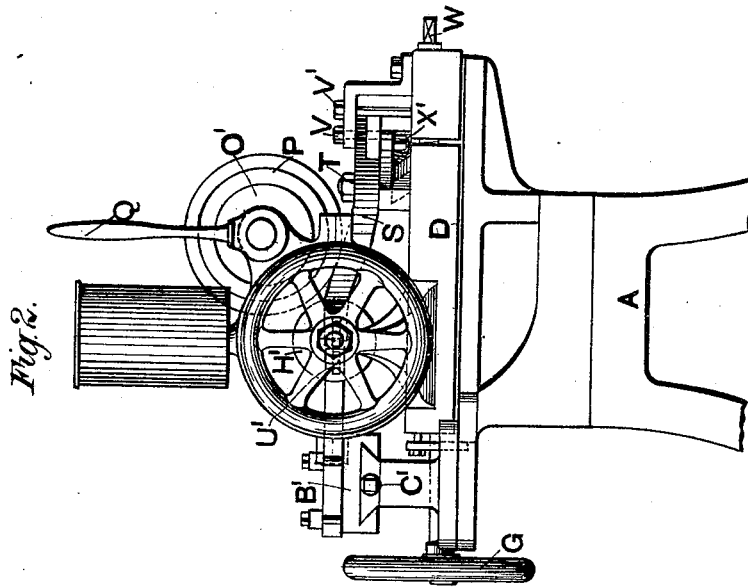

Witnesses:

Chas. A. Saal

Wm. A. Rosenbaum

Inventors:

Richard S. Wood &
Earnest N. Dunderdale

by W. J. Johnston

Attorney

(No Model.)

3 Sheets—Sheet 2.

R. S. WOOD & E. N. DUNDERDALE.

MACHINE FOR CHAMFERING AND FACING SCREW NUTS.

No. 371,654.

Patented Oct. 18, 1887.

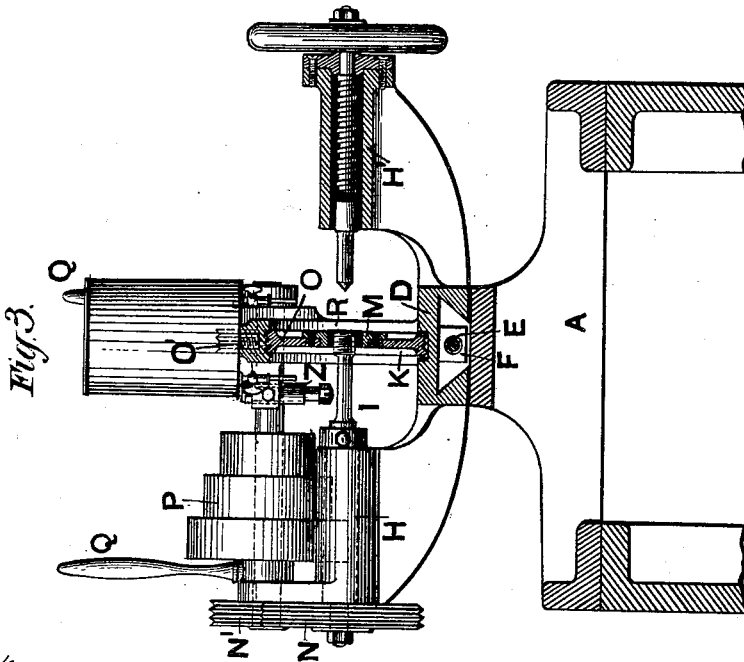
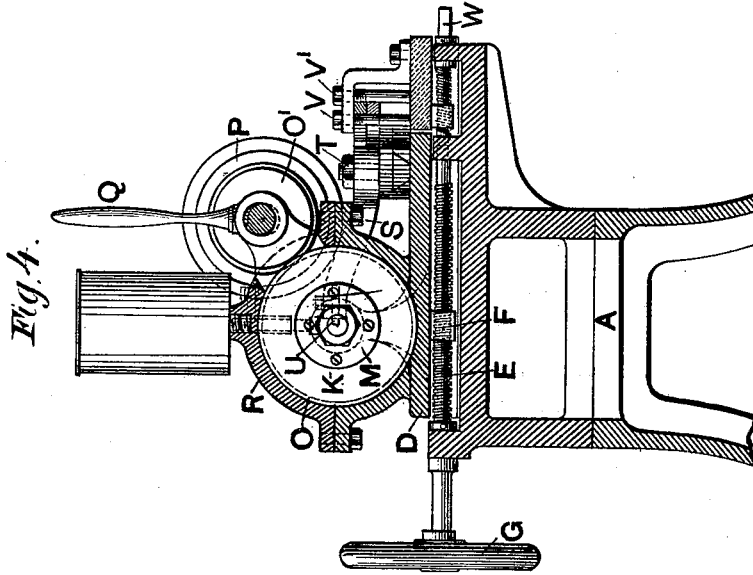

Witnesses:

Chas. A. Saal

Wm. A. Reinbaum

Inventors:

Richard S. Wood
Earnest N. Dunderdale

by *W. D. Johnston* Atty.

(No Model.)

3 Sheets—Sheet 3.

R. S. WOOD & E. N. DUNDERDALE.

MACHINE FOR CHAMFERING AND FACING SCREW NUTS.

No. 371,654.

Patented Oct. 18, 1887.

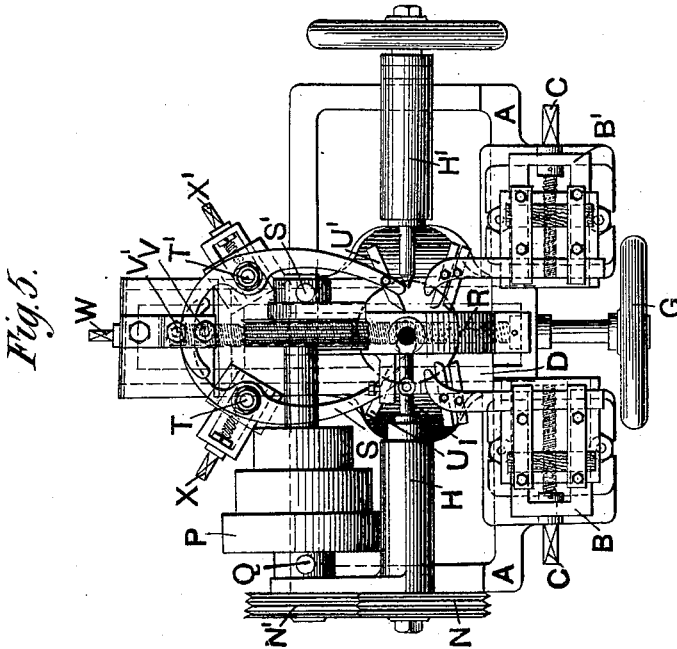

Witnesses:

Chaas Saal

Wm. Rosubain

Inventors:

Richard S. Wood

Earnest N. Dunderdale

by W. D. Johnston
Atty.

UNITED STATES PATENT OFFICE.

RICHARD SAMUEL WOOD AND ERNEST N. DUNDERDALE, OF MANCHESTER,
COUNTY OF LANCASTER, ENGLAND.

MACHINE FOR CHAMFERING AND FACING SCREW-NUTS.

SPECIFICATION forming part of Letters Patent No. 371,654, dated October 18, 1877.

Application filed May 10, 1887. Serial No. 237,704. (No model.) Patented in England September 25, 1886, No. 12,186, and October 12, 1886, No. 12,969.

To all whom it may concern:

Be it known that we, RICHARD SAMUEL WOOD and ERNEST N. DUNDERDALE, subjects of the Queen of Great Britain, and residents of Manchester, in the county of Lancaster and Kingdom of Great Britain, have invented certain new and useful Improvements in Machines for Chamfering and Facing Screw-Nuts, (the same having been patented in Great Britain September 25, 1886, No. 12,186, and October 12, 1886, No. 12,969,) of which the following is a specification.

This invention relates to machinery or apparatus for facing and chamfering screw-nuts, and it has for its object to effect the facing and chamfering on each side of the nut without re-chucking successively or simultaneously.

The accompanying drawings, which are hereinafter referred to, illustrate a machine or apparatus constructed according to these improvements.

Figure 1 is a front view. Fig. 2 is an end view. Fig. 3 is a front view, partly in section. Fig. 4 is a transverse section, and Fig. 5 is a plan.

In each of the figures similar letters are employed to denote the similar parts.

A is the support or under framing.

B B' are slide-rests, the slides of which may be adjusted by screws having squares C C' formed upon their ends, or they may be provided with other devices by means of which their rotation may be effected.

D is a transverse slide operated by the screw E, which works in the nut F, attached to the transverse slide.

G is a handle for actuating the screw E.

H H' are two head stocks practically equivalent to the head-stocks of an ordinary lathe.

I is a mandrel having a screwed head of larger diameter than the stem of the mandrel. This mandrel has its head screwed to correspond and fit within the particular size of nut to be operated on, and the screwed part is a little shorter than the depth of the nut.

K is a disk having a central perforation corresponding to the dimensions and shape of the nut.

As represented in the drawings, Figs. 3 and

4, the nut L is carried in a chuck-bush or removable piece, M. This arrangement obviates a change of the disk K when the size of the nut is altered. The disk K is concentric with the mandrel, and is arranged so that it may be rotated at an equal rate therewith. The desired rotation of the mandrel and of the disk may be effected very conveniently by means of the two pairs of friction-pulleys N N' and O O', N being equal to O, and N' to O'. The friction pulleys may be driven from the cone-pulley P, and may be put in gear therewith by means of the handle Q, which is connected with an eccentric. This device for pulling the friction-pulleys into gear is equivalent and similar to the corresponding device in the back gear of a lathe. It will be seen that the friction-pulley O may, as shown in the drawings, be formed upon the disk K. It may be carried or borne upon smaller pulleys or rollers arranged around its circumference, or, as represented, it may bear in the annular casing R, a portion of the casing being cut away to allow the frictional surfaces to come into contact.

S S' are two curved or bent levers or tool-carriers. Each tool-carrier is pinned or pivoted at T T' to a pin or pivot carried by the traversing slide D. Their inner ends carry the chamfering-tools U U', and their outer ends engage with or are controlled by two stationary bolts, V V', the position of which may be adjusted by the screw W, and they may also be connected by spiral springs to the pins T T' to assist their return motion.

The tool-carriers S S' may have the positions of their pins or pivots adjusted, as may be required, by the screws X X'. The surfacing and leveling tools are carried by the tool-holders in the slide-rests B B'.

Z is an adjustable stud or bolt, which may be set nearer to or farther from the disk K, as may be required in order to bring it into contact with the nut when the latter is in its correct position in the disk for being operated on. By this means it may be insured that the same amount of metal shall be taken off each side of the nut. When one face of the nut only is required to be beveled, a surfacing

and beveling tool or tools will be employed with one of the slide-rests, and a surfacing-tool only with the others.

For the sake of clearness, some of the parts which would actually be in sight have been omitted from some of the figures.

In operating the machine or apparatus a mandrel, I, of the required size is fixed in position, the various cutting-tools are changed, altered, or adjusted, so as to produce their respective cuts on the nut to bring it to the desired form and dimensions, the adjustable stop or bolt Z is secured in its proper position, and a suitable bush or chuck for holding the nut is secured in the disk. The friction-pulleys being out of gear, the apparatus may be set in motion, when the mandrel will revolve and the disk will remain stationary. A blank screwed nut may now be presented to the head of the mandrel through the opening in the center of the disk, when the screwed part of the mandrel will engage with the thread of the nut, which is prevented from rotating by being held within the stationary disk. The nut will consequently be screwed upon the head of the mandrel until it comes in contact with the adjustable stop Z. The friction-pulleys are then put into gear by the handle Q, whereupon the mandrel with the nut thereon and the disk with the nut therein are driven at the same speed. The handle upon the screw actuating the traversing slide is then rotated, so as to bring the surfacing and beveling tools into operation upon the nut. At the same time, the centers of the curved or bent tool-carriers S S' being moved with the traversing slide, and the tails of the tool-carriers being prevented from partaking of the transverse motion by the stationary studs or bolts V V', the tool ends of the carriers swing through the arcs of circles around T T' until their cutting-tools come into contact with and chamfer each end of the bore of the nut. When the cuts are completed, the motion of the hand-wheel, and consequently of the trav-

ersing slide, is reversed, and the tools are thereby removed, so as to permit the withdrawal of the nut.

It will be found more generally convenient to construct the machine or apparatus substantially as hereinbefore described; but it is obvious that the traversing slide, slide-rests, bent or curved tool-carriers, disk, mandrel, adjusting-bolts, screws, and friction-gear may be adapted to or arranged or combined with an ordinary lathe. It is evident, also, that various mechanical modifications of the details of the apparatus may be effected without departing from our invention, and that some of them may be omitted or other parts or details be added thereto, as may be required, under especial circumstances or conditions.

Having described our invention, we claim—

1. In a machine or apparatus for chamfering and facing screw-nuts, the combination, with operating mechanism, of a traversing slide, a perforated disk or nut-carrier, a mandrel with an enlarged screwed head, two slide-rests, and an adjustable stop, Z, substantially as hereinbefore described, and as illustrated by the accompanying drawings.

2. In a machine or apparatus for chamfering and facing screw-nuts, the combination, with operating mechanism, of a traversing slide, a perforated disk or nut-carrier, a mandrel with an enlarged screwed head, one or two curved or bent and pivoted tool-carriers, two slide-rests, and an adjustable nut-stop, substantially as hereinbefore described, and illustrated by the accompanying drawings.

In testimony that we claim the foregoing as our invention we have signed our names, in presence of two witnesses, this 6th day of December, 1886.

RICHARD SAMUEL WOOD.
ERNEST N. DUNDERDALE.

Witnesses:

ROBT. MATHIESON,
WM. E. HEYS.